



# DAEWOO®



\*Please refer to the warranty section for terms of your extended guarantee



## DEEP FILL SANDWICH TOASTER

## READING AND STORING THE USER MANUAL



Before using this product, please read through this manual carefully paying particular attention to the safety instructions. Failure to do so may result in personal injury or damage to the product.

Carefully save this instruction manual for future reference. Ensure the user manual is included when passing the product on to any third parties.

## IMPORTANT SAFETY INSTRUCTIONS FOR PROPER USE

When using electrical appliances, basic safety precautions should always be followed.

Only use the product as described in this user manual. Any other use is considered improper and may result in damage to property or persons. The manufacturer or vendor cannot be held liable for damages or injury incurred through improper or incorrect use.

- **Read and familiarise yourself with all operating instructions before using this sandwich toaster.**
- Before plugging your unit into the mains, visually check that it is intact and has not suffered any transit damage.
- Check that the voltage indicated on the data plate corresponds with that of the local network before connecting the appliance to the mains power supply.
- **DO NOT** use this product with a programmer, timer, separate remote-control system or any other such device.
- **DO NOT** immerse this appliance in water or any other liquids.
- Cooking appliances should be positioned in a stable situation with the handles (if any) positioned to avoid spillage of liquids.
- **DO NOT** touch hot surfaces. Accessible surfaces are liable to get hot during use. Always use the handle. 
- Oven gloves should be used whilst using the sandwich toaster.
- Hot steam may be released when opening and closing the appliance during use – Risk of scalding!

- Avoid moving the appliance whilst it is still hot or contains hot food.
- Turn the appliance off and disconnect from the mains and let it cool sufficiently before moving it.
- Close supervision is required when using this appliance near children.
- Never leave this appliance within reach of children.
- This appliance shall not be used by children from 0 to 8 years.
- This appliance can be used by children aged from 8 years and above and persons with reduced physical, sensory or mental capabilities or lack of experience and knowledge if they have been given supervision or instruction concerning use of the appliance in a safe way and understand the hazards involved.
- Children shall not play with the appliance.
- Keep the appliance and its cord out of reach of children less than 8 years.
- Cleaning and user maintenance shall not be made by children.
- **DO NOT** leave the appliance unattended during use.
- **DO NOT** leave the appliance unattended whilst connected to the mains supply.
- Always use this appliance on a solid, level, non-flammable surface.
- **DO NOT** use this appliance outdoors.
- It is imperative to unplug the power cord after the appliance has been used, before it is cleaned and whilst being repaired.
- Regular, periodic checks should be carried out on the supply cord to ensure no damage is evident. Should there be any signs of damage the appliance should not be used.
- If the supply cord is damaged it is to be replaced by qualified personnel in order to avoid a hazard.
- **DO NOT** operate this appliance with a damaged plug or

cord, after a malfunction or after being dropped or damaged in any way.

- **DO NOT** allow the mains cable to hang over sharp edges or come in contact with hot surfaces.
- Allow the unit to cool before storage.
- Never place the appliance near to flammable material or high pressure containers.
- This appliance is intended for household use only and should not be used for industrial purposes.
- **DO NOT** use any accessories or attachments with this appliance other than those supplied or recommended by supplier.
- **DO NOT** use this appliance for anything other than its intended use.
- **DO NOT** push objects into any openings as damage to the appliance and/or electric shock may occur.
- Ensure appliance is situated in an open area, do not allow it to come in contact with cupboards, curtains, wall coverings, clothing or other flammable materials.
- Unplug after each use. Grasp the plug, not the cord.
- Do not cover this appliance.
- Never place this appliance on an electric, gas, or any other type of hob.
- Ensure adequate ventilation whilst cooking foods that are prone to giving off smoke.
- **DO NOT** use this appliance with an extension lead.
- **⚠ WARNING! DO NOT attempt to move the sandwich toaster whilst it is hot.**

**THIS APPLIANCE MUST BE EARTHED**

### Explanation of Symbols

The following warning symbols or words are used in this instruction manual:



Products labelled with UK Conformity Assessment identifies products conforming to UK statutory requirements.



Products labelled with this symbol conform to applicable provisions of the European Economic Area.



This symbol provides useful additional information on the use of this product.

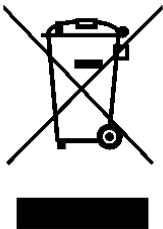

You should now recycle your waste electrical goods and in doing so help the environment. This symbol means waste electrical products at the end of their useful life should not be disposed of with normal household waste. Please ensure it is taken to a suitable facility for disposal. Check with your Local Authority or retailer for recycling advice or visit [www.recycle-more.co.uk](http://www.recycle-more.co.uk) or [www.weeeireland.ie](http://www.weeeireland.ie) enter your postcode to find out your nearest recycling site.



This designates a hazard with moderate risk, which may result in severe injury or death if not adhered to.

- **PLEASE NOTE: Do not use the Sandwich Toaster in front of, near or below combustible materials such as plastics, curtains or cupboards, etc.**
- **Do not place the appliance against a wall or against other appliances. Leave at least 10cm minimum free space on the back and sides and 10cm minimum free space above the appliance.**
- **Do not place anything on top of the appliance.**

### Before First Use of Your Sandwich Toaster

Remove all packing materials including in between the plates inside the sandwich toaster and discard responsibly.

Before using the sandwich toaster for the first time, open the sandwich toaster and wipe over both cooking plates using a soft, clean damp cloth and dry with a cloth or paper towel.

**i** Whilst using your sandwich toaster for the first time it may emit a little smoke and odour which will soon pass. This is the protective coating applied to elements during transit and does not affect your appliance.

Ensure all parts are present (if applicable) see Description of Parts below.

### Description of Parts

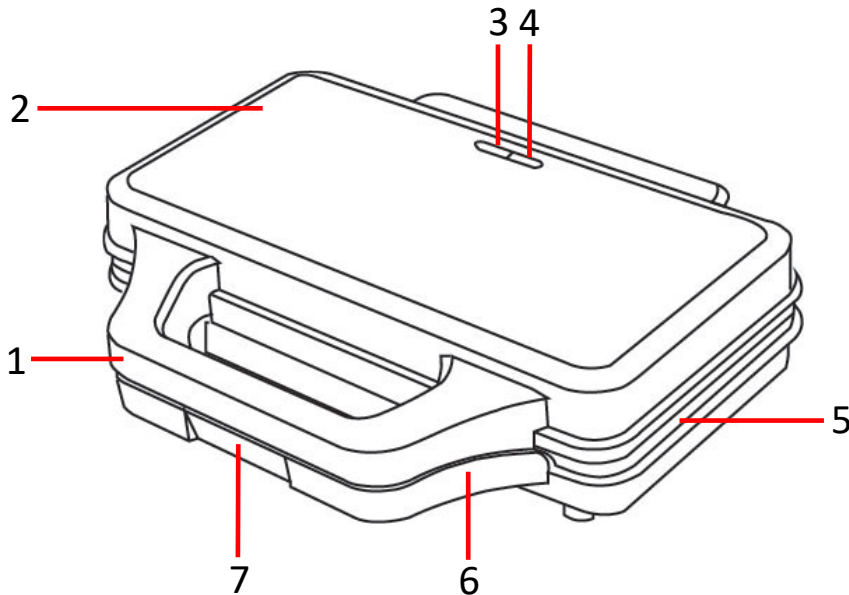

1. Upper Handle
2. Lid
3. Power Indicator
4. Ready Indicator
5. Non stick cooking plates
6. Lower Handle
7. Locking Clip

### Instructions for Use

1. Place the sandwich toaster on a level, non-flammable surface.
2. With the **Lid** (2) closed, insert the plug (with dry hands) into the mains socket and switch the socket on (if applicable). The red **Power Indicator** (3) will illuminate and the grill will begin to heat.
3. Once the sandwich toaster is at the cooking temperature, the red **Power Indicator** (3) and the green **Ready Indicator** (4) will both illuminated. This light will come on and go off during toasting – this is quite normal.
4. Spread the outside of 4 slices of bread with butter or a spread suitable for cooking. This gives the toasted sandwich a golden brown colour during cooking.



5. Place 2 of the slices bread onto the bottom plate, butter side down and the crusts facing outwards as shown below:

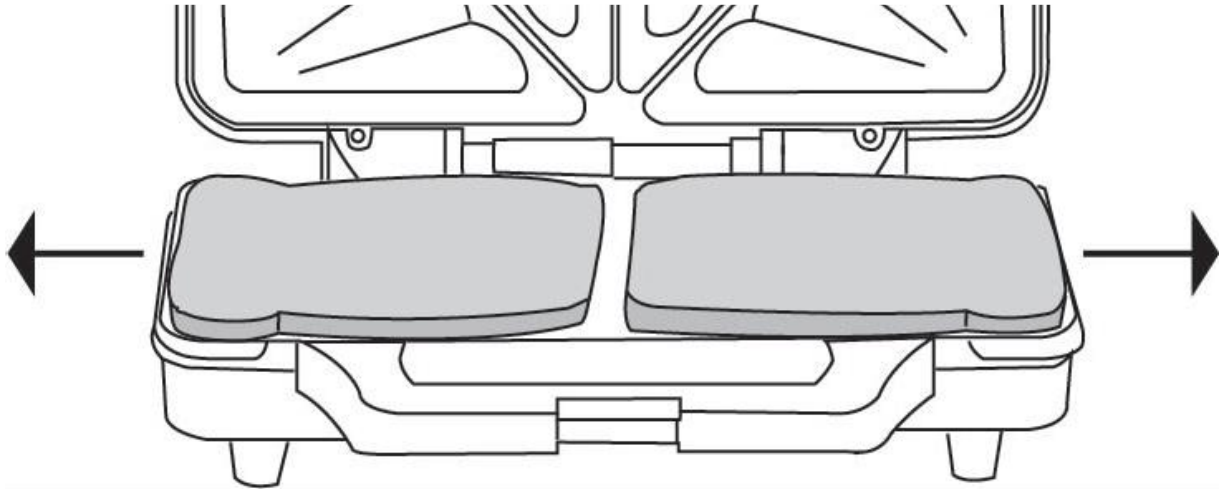

6. Add the filling onto the bread leaving a gap around the edge to allow the sandwich to be sealed. Never over fill the sandwich.
7. Place the remaining 2 slices of bread onto the filling, butter side up.
8. Close the **Lid** (2) and lock the handles together using the **Locking Clip** (7). Leave the sandwich for approximately 4-5 minutes until golden and cooked, or leave for more or less cooking time according to taste.
9. Using a tea towel or oven gloves release the **Locking Clip** (7) and open the **Lid** (2), be careful as hot steam can escape.
10. Using a non-metallic utensil remove the toasted sandwich.
11. Unplug from the mains supply.
12. Care should be taken when eating as filling can be very hot.

- i** It is recommended that the bread be buttered on the outside to prevent it sticking to the plates.
- i** During cooking, the green ready indicator will cycle on and off – this is quite normal.
- i** Always use non-metallic utensils with the sandwich toaster such as wood or plastic. Metal utensils will damage the non-stick surface of the cooking plates.

### **Cleaning Your Sandwich Toaster**

- Always unplug the toaster from the mains power supply before cleaning.
- Allow the unit to cool before cleaning.
- Do not clean any part of your sandwich toaster in a dishwasher.
- Do not submerge any part of the main body or mains cable in water or any other liquids.
- Wipe excess oil from the plates, with kitchen roll or similar.
- Wipe clean the outside of the main body and the plates with a soft damp cloth.
- Never clean any part of the sandwich toaster with harsh or abrasive cleaners.

### **Storing Your Sandwich Toaster**

To store, wrap the cord around the pedestal on the base as shown below. Store in an upright position:



### **Non-Rewireable Mains Plug**

If your appliance is supplied with a non-rewireable plug fitted to the mains lead and should the fuse need replacing, you must use an ASTA approved one (conforming to BS 1362 of the same rating). Never use a plug with the fuse cover missing. If in doubt, consult a qualified electrician.

If you need to remove the plug – DISCONNECT FROM THE MAINS – and then cut it off the mains lead and immediately dispose of it safely. Never attempt to reuse the plug or insert it into a socket outlet as there is a danger of electric shock.

### **Technical Specification**

Model Number	SDA1389
Rated Voltage	220-240V~ 50/60Hz
Rated Power	900W
Protection Class	I (This appliance must be earthed)

## Recycling Information

### Disposal of the Packaging

Dispose of paper and cardboard in appropriate paper re-cycling facilities.

Dispose of plastics in the appropriate plastics collection service.

Dispose of non-recyclable plastics in the appropriate plastics collection service.

### Disposal of the Product

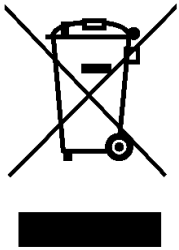

You should now recycle your waste electrical goods and in doing so help the environment. This symbol means waste electrical products at the end of their useful life should not be disposed of with normal household waste. Please ensure it is taken to a suitable facility for disposal. Check with your Local Authority or retailer for recycling advice or visit [www.recycle-more.co.uk](http://www.recycle-more.co.uk) or [www.weeeireland.ie](http://www.weeeireland.ie) enter your postcode to find out your nearest recycling site.

## **Customer Support**

Should you require any product information, replacement parts or accessories, please contact our customer care team on 0161 831 7879 (8.30am-4.30pm Monday to Thursday, 8.00am-4.00pm Friday) and select option 3 or by contacting us via email: [help@daewooelectricals.com](mailto:help@daewooelectricals.com).

- Replacement parts and accessories are guaranteed for 1 year from the date of purchase.
- It is important to note that your warranty becomes invalid should non Daewoo parts or accessories be used with this appliance.

UK  
CA

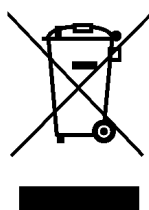



# DAEWOO®

## WARRANTY

*Thank you for purchasing your Daewoo product.*

*As part of our commitment to quality, we are offering you an extra 2 years warranty in addition to your 1 year guarantee*

Your Daewoo product is guaranteed for 1 year from the date of original purchase, with proof of purchase or receipt. If any defect should occur due to faulty workmanship or material, your faulty product should be returned to the place of purchase, replacement or refund is at the discretion of the retailer.

The guarantee is subject to the following provisions:

- The product must be correctly installed and operated in accordance with the requirements contained in the instruction manual.
- The product must be used solely for domestic purposes.
- It does not cover general wear and tear, damage, misuse or any consumable parts.
- The guarantee will be rendered invalid if the product is re-sold or has been damaged through inexpert repair.
- The guarantee is only valid within the UK and Eire.

Your standard 1 year guarantee will only be extended to the maximum available for your individual product upon registration. (Note: products must be registered individually and covers the main body and housing). If you do not register your product within 28 days of the original purchase date, your product will only be guaranteed for 1 year.

***To validate your extended 2 year warranty\* please register your purchase online within 28 days of the original purchase date by registering at:***

***<https://help.daewooelectricals.com>***

***or***

***[Contact Us \(daewooelectricals.com\)](https://www.daewooelectricals.com)***

\*Your extended warranty is only valid with proof of purchase receipt and subject to the conditions outlined above.

Daewoo is a registered trademark.  
Produced and imported under licence by  
Eurosonic Group Limited  
Brightgate House  
1 Brightgate Way  
Manchester M32 0TB UK  
EU Rep: EuroSonic Magppie (ESM) Ltd. Ireland D05 X006  
[www.esgltd.com](http://www.esgltd.com)