

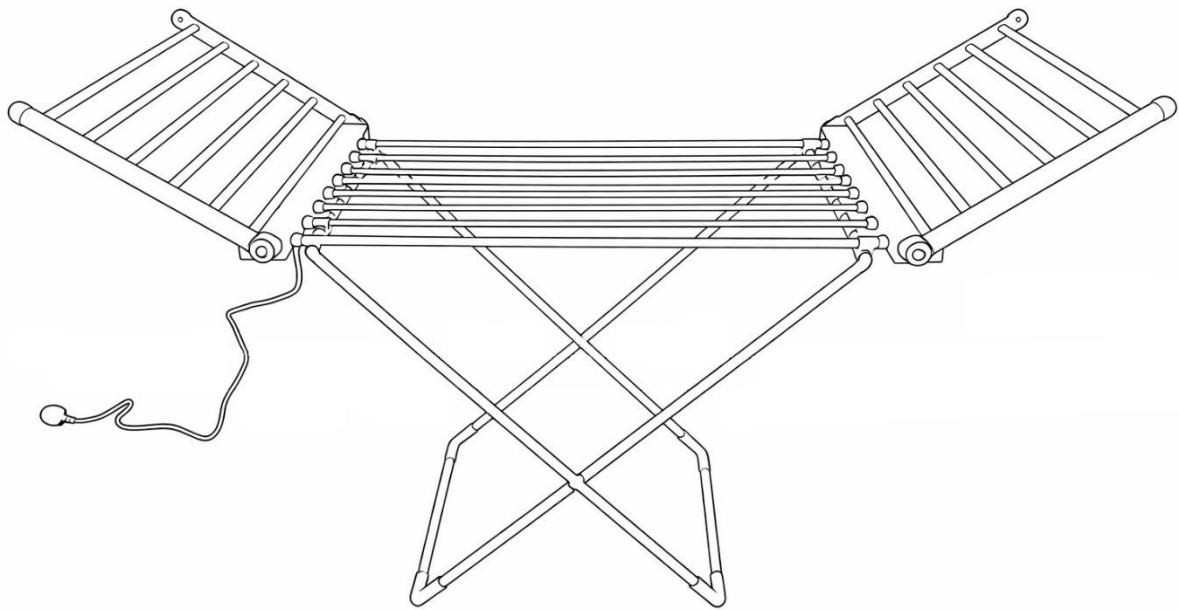



Heated Airer with Wings

HEA1874
User Manual



1. Check that the product is intact and undamaged and all parts are present.
2. Dispose of packaging materials responsibly.
3. No tools are required to assemble your heated airer, it is designed to be used straight from the box.
4. Check the washcare label in the clothes before using this airer, ensure that there are no specific drying requirements such as dry flat, drip dry, etc.

Safety Advice

- **IMPORTANT** – The first step you need to take is to ensure your safety! Please take time to read and understand these instructions before using the product. 
- Please keep these instructions for future reference.
- **DO NOT** install the appliance directly below an electrical socket.
- **DO NOT** use this Heated Airer with a programmer, timer, separate remote-control system or any other device that switches the heater on automatically, since a fire risk exists if the Heated Airer is positioned incorrectly.
- **DO NOT** use this Heated Airer with an extension cable.
- **WARNING!** This appliance is intended only for drying textiles washed in water.
- **CAUTION** — **Some parts of this product can become very hot and cause burns. Particular attention has to be given where children and vulnerable people are present.**
- Check that the voltage indicated on the data plate corresponds with that of the local network before connecting the appliance to the mains power supply.
- Close supervision is required when using this appliance near children.
- Never leave this appliance within reach of children.
- This appliance can be used by children aged from 8 years and above and persons with reduced physical, sensory or mental capabilities or lack of experience and knowledge if they have been given supervision or instruction concerning use of the appliance in a safe way and understand the hazards involved.
- Children shall not play with the appliance. Cleaning and user maintenance shall not be made by children without supervision.





- Children of less than 3 years should be kept away unless continuously supervised.
- Children aged from 3 years and less than 8 years shall only switch on/off the appliance provided that it has been placed or installed in its intended normal operating position and they have been given supervision or instruction concerning use of the appliance in a safe way and understand the hazards involved. Children aged from 3 years and less than 8 years shall not plug in, regulate and clean the appliance or perform user maintenance.
- **DO NOT** use this Heated Aired in the immediate surroundings of a bath, a shower or a swimming pool.
- **DO NOT** immerse the appliance or its cord in water or any other liquids.
- Always use this appliance on a solid, level, non-flammable surface.
- **DO NOT** use this appliance outdoors.
- It is imperative to unplug the power cord after the appliance has been used, before it is cleaned and whilst being repaired.
- Repairs to electrical appliances should only be performed by a qualified electrician. Improper repairs may place user at serious risk.
- **DO NOT** operate this appliance with a damaged plug or cord, after a malfunction or after being dropped or damaged in any way.
- Regular, periodic checks should be carried out on the mains cable to ensure no damage is evident. Should there be any signs of damage the appliance should not be used. If the power cable is damaged, it should only be replaced by the manufacturer or a suitable qualified after-sales-service in order to avoid a hazard
- **DO NOT** allow the mains cable to hang over sharp edges or come in contact with hot surfaces.
- **DO NOT** run the mains cable under carpets, rugs, etc.
- Allow the unit to cool before storage.

- Before cleaning, disconnect the appliance from the mains supply and allow to cool.
- Never place the appliance near to flammable material or high pressure containers. (e.g., Paper, wood, petrol, solvents, spray canisters etc.)
- This appliance is intended for household use only and should not be used for industrial purposes.
- **DO NOT** use any accessories or attachments with this appliance other than those supplied or recommended by supplier.
- **DO NOT** use this appliance for anything other than its intended use.
- **DO NOT** push objects into any openings as damage to the appliance and/or electric shock may occur.
- Ensure appliance is situated in an open area.
- The appliance should not be installed in areas which have a fire-risk, such as garages, stables or wooden sheds; this is applicable also for rooms in which highly inflammable gasses or dust can develop. Danger of fire!!
- Unplug after each use. Grasp the plug, not the cord.

THIS APPLIANCE MUST BE EARTHED

During the first few minutes of initial use, you may notice a slight odour and a little smoke. This is normal and will quickly disappear, it is the coating applied to the heating elements to prevent any corrosion during transit.

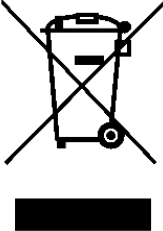
The following warning symbols or words are used in this instruction manual:

	<p>Products labelled with UK Conformity Assessment identifies products conforming to UK statutory requirements</p>
	<p>Products labelled with this symbol conform to applicable provisions of the European Economic Area.</p>
	<p>You should now recycle your waste electrical goods and in doing so help the environment. This symbol means waste electrical products at the end of their useful life should not be disposed of with normal household waste and not sent to landfill. Please ensure it is taken to a suitable facility for disposal. Check with your Local Authority or retailer for recycling advice or visit www.recycle-more.co.uk or www.weeeireland.ie enter your postcode to find out your nearest recycling site.</p>
<p>WARNING!</p>	<p>This designates a hazard with moderate risk, which may result in severe injury if not adhered to.</p>
	<p>This symbol indicates that the supply uses an alternating current mains supply.</p>
	<p>This symbol indicates that the product is class I and therefore requires an earth connection.</p>

1. Heated Wings (x2)
2. Main Body
3. Stand
4. Mains Cable
5. On/Off Switch

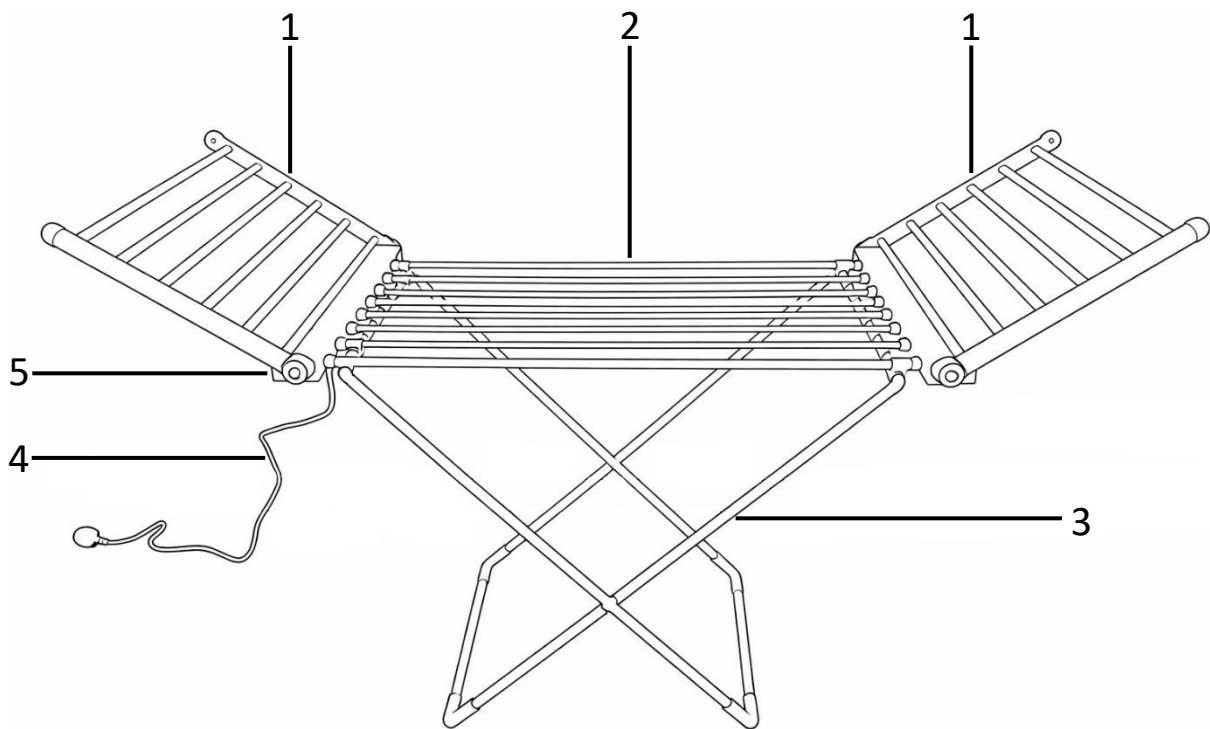

WARNING! Ensure that the **Mains Cable** (4) does not get trapped in the ailer whilst unfolding the ailer or folding it closed for storage.

Step 1

Slide the non-fixed end of the **Stand** (3) to the opposite end of the Ailer **Main Body** (2) in the direction of the arrow as shown.

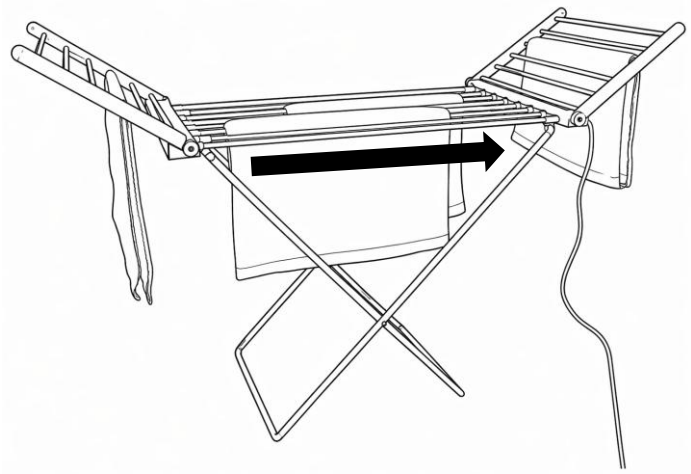

Step 2

Fold the **Heated Wings** (1) outwards.

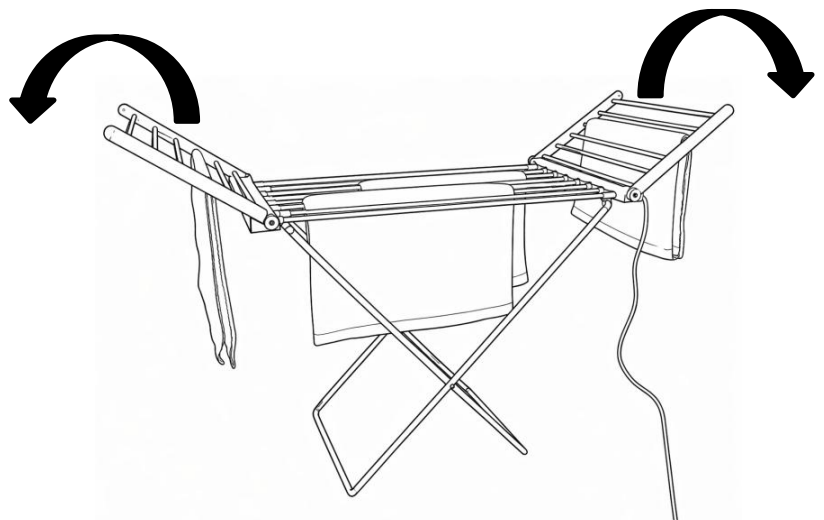

Step 1

Insert the mains plug into the nearest socket outlet and switch the socket on (if applicable).

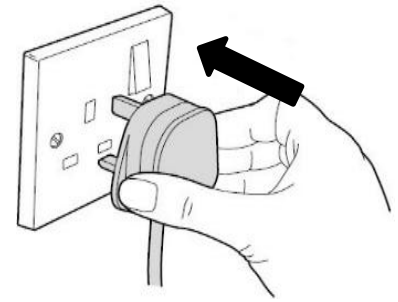

Step 2

Press the **On/Off Switch (5)** to the ON 'I' position to operate the Heated Airer, the switch will illuminate and the rails of the airer will begin to warm up. Press the switch to OFF 'O' position to switch off the airer.

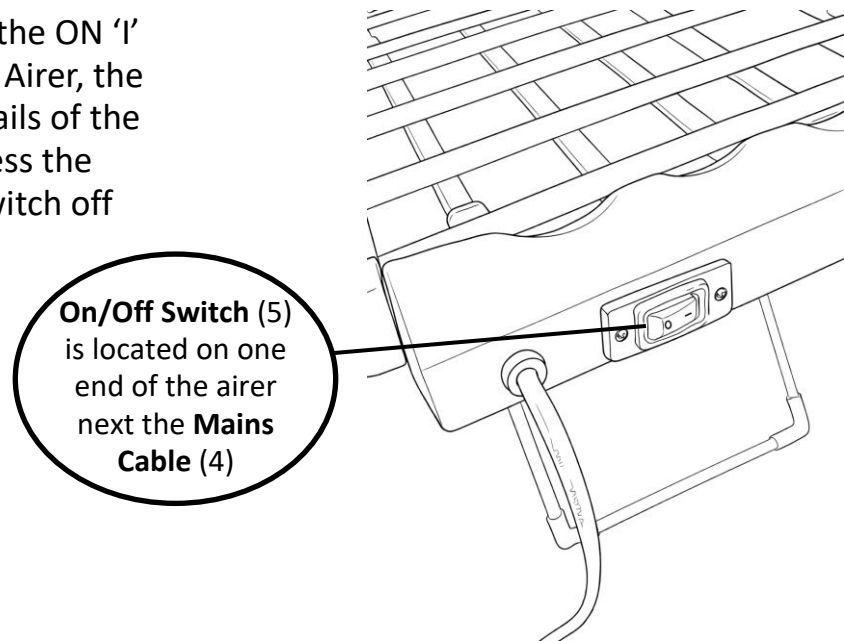

Step 3

After a short time (approximately 5 minutes) the Heated Airer will reach its operating temperature and is ready for use.

NB Do not overload the Heated Airer, the maximum load is 15kg.

Step 4

After use switch off the Heated Airer by pressing the **On/Off Switch (5)** to the 'O' position and unplug from the mains.

Step 5

Allow the unit to cool before storage.

Step 6

Fold up the Heated Airer following the reverse procedure as above and store in a cool dry place.

- Always disconnect the Airing from the mains power supply and allow to cool before cleaning.
- Clean outside of the Airing with a clean damp cloth. Never clean with harsh or abrasive cleaners.
- Do not submerge any part of Airing in water or any other liquids.

Technical Specification

Model Number	HEA1874
Rated Voltage	220-240V ~ 50/60Hz
Rated Power	230W
IP Rating	IPX1
Protection Class	I (This appliance must be earthed)
Maximum Load	15Kg
ErP: Power consumption of equipment in off mode shall not exceed 0.30W	0.0W
This equipment complies with Annex III of Commission Regulation (EU) 2023/826	

The Mains Plug

If your appliance is supplied with a non-rewireable plug fitted to the mains lead and should the fuse need replacing, you must use an ASTA approved one (conforming to BS 1362 of the same rating). If in doubt, consult a qualified electrician. Never use a plug with the fuse cover missing.

If you need to remove the plug – **DISCONNECT FROM THE MAINS** – and then cut it off the mains lead and immediately dispose of it safely. Never attempt to reuse the plug or insert it into a socket outlet as there is a danger of electric shock.

Disposal of the Packaging

Dispose of paper and cardboard in appropriate paper re-cycling facilities.

Dispose of recyclable plastics in appropriate plastic re-cycling facilities.

Dispose of non-recyclable plastics in the appropriate plastics collection service.

Disposal of the Product

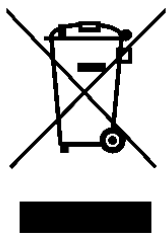

You should now recycle your waste electrical goods and in doing so help the environment. This symbol means waste electrical products at the end of their useful life should not be disposed of with normal household waste and not sent to landfill. Please ensure it is taken to a suitable facility for disposal. Check with your Local Authority or retailer for recycling advice or visit www.recycle-more.co.uk or www.wEEEireland.ie enter your postcode to find out your nearest recycling site.

Customer Support

Should you require any product information, replacement parts or accessories, please contact our customer care team on 0161 831 7879 (8.30am-4.30pm Monday to Thursday, 8.00am-4.00pm Friday) and select option 3 or by contacting us via email: help@daewooelectricals.com.

- Replacement parts and accessories are guaranteed for 1 year from the date of purchase.
- It is important to note that your warranty becomes invalid should non Daewoo parts or accessories be used with this appliance.



Thank you for purchasing your Daewoo product.

As part of our commitment to quality, we are offering you an extra 2 years warranty in addition to your 1 year guarantee

Your Daewoo product is guaranteed for 1 year from the date of original purchase, with proof of purchase or receipt. If any defect should occur due to faulty workmanship or material, your faulty product should be returned to the place of purchase, replacement or refund is at the discretion of the retailer.

The guarantee is subject to the following provisions:

- The product must be correctly installed and operated in accordance with the requirements contained in the instruction manual.
- The product must be used solely for domestic purposes.
- It does not cover general wear and tear, damage, misuse or any consumable parts.
- The guarantee will be rendered invalid if the product is re-sold or has been damaged through inexpert repair.
- The guarantee is only valid within the UK and Eire.

Your standard 1 year guarantee will only be extended to the maximum available for your individual product upon registration. (Note: products must be registered individually and covers the main body and housing). If you do not register your product within 28 days of the original purchase date, your product will only be guaranteed for 1 year.

To validate your extended 2 year warranty* please register your purchase online within 28 days of the original purchase date by registering at:

<https://help.daewooelectricals.com>

or

[Contact Us \(daewooelectricals.com\)](https://www.daewooelectricals.com)

*Your extended warranty is only valid with proof of purchase receipt and subject to the conditions outlined above.

Daewoo is a registered trademark.
Produced and imported under licence by
Eurosonic Group Limited
Brightgate House
1 Brightgate Way
Manchester M32 0TB UK
EU Rep: EuroSonic Magppie (ESM) Ltd. Ireland D05 X006
www.esgltd.com
Made in China