



# DAEWOO®



\*Please refer to the warranty section for terms of your extended guarantee



## TORNADO UP-LIFT LITE

CORDLESS UPRIGHT & HANDHELD VACUUM

## Contents

Page No.	
2	Contents
3	Reading and Storing the User Manual
3	Important Safety Instructions for Proper Use
6	Explanation of Symbols
7	Description of Parts & Accessories
8	Assembling Your Vacuum Cleaner
9	Before First Use of Your Vacuum Cleaner
9	Charging the Battery
9	Using Your Vacuum Cleaner
10	Changing the Power level of Your Vacuum Cleaner
11	Using Your Vacuum Handheld
11	Attaching the Multi Tool
12	Emptying Your Vacuum Cleaner
13	Cleaning the Filter Assembly
15	Reassembling Your Vacuum
16	Recommended Filter Cleaning Intervals
17	Removing the Brush Bar for Cleaning
17	Replacing the Brush Bar
18	Care and Maintenance of Your Vacuum Cleaner
18	Storing Your Vacuum Cleaner
18	Technical Specification
19	Troubleshooting Guide
20	Recycling Information
21	Customer Support
Back Page	Warranty Information

## READING AND STORING THE USER MANUAL



Before using this product, please read through this manual carefully paying particular attention to the safety instructions. Failure to do so may result in personal injury or damage to the product.

Carefully save this instruction manual for future reference. Ensure the user manual is included when passing the product on to any third parties.

## IMPORTANT SAFETY INSTRUCTIONS FOR PROPER USE

**When using electrical appliances, basic safety precautions should always be followed.**

Only use the product as described in this user manual. Any other use is considered improper and may result in damage to property or persons. The manufacturer or vendor cannot be held liable for damages or injury incurred through improper or incorrect use.

- Read and familiarise yourself with all operating instructions before using this Vacuum Cleaner.
- Before plugging your unit into the mains, visually check that the unit is intact and has not suffered any transit damage.
- Check that the voltage indicated on the data plate corresponds with that of the local network before connecting the appliance to the mains power supply.
- This appliance can be used by persons with reduced physical, sensory or mental capabilities or lack of experience and knowledge if they have been given supervision or instruction concerning use of the appliance in a safe way and understand the hazards involved.
- Children shall not play with the appliance.
- Keep the appliance and its cord out of reach of children less than 8 years when it is energised or cooling down.
- **DO NOT** immerse the appliance or its cord in water or any other liquids.
- **DO NOT** leave the appliance unattended during use.
- **DO NOT** leave the appliance unattended whilst connected to the mains supply.

- 
- **DO NOT** use this appliance outdoors.
  - It is imperative to unplug the power cord after the appliance has been used, before it is cleaned and whilst being repaired.
  - Repairs to electrical appliances should only be performed qualified personnel. Improper repairs may place user at serious risk.
  - **DO NOT** operate this appliance with a damaged plug or cord, after a malfunction or after being dropped or damaged in any way.
  - Regular, periodic checks should be carried out on the mains cable to ensure no damage is evident. Should there be any signs of damage the appliance should not be used.
  - If the power cable is damaged, it should only be replaced by suitable qualified personnel in order to avoid a hazard
  - **DO NOT** allow the mains cable to hang over sharp edges or come in contact with hot surfaces.
  - Allow the unit to cool before storage.
  - Before cleaning, disconnect the appliance from the mains supply and allow to cool.
  - This appliance is intended for household use only and should not be used for industrial purposes.
  - **DO NOT** use any accessories or attachments with this appliance other than those supplied or recommended by supplier.
  - **DO NOT** use this appliance for anything other than its intended use.
  - **DO NOT** push objects into any openings as damage to the appliance and/or electric shock may occur.
  - Unplug after each use. Grasp the plug, not the cord.
  - **DO NOT** pull or carry the Vacuum Cleaner by the electrical cord, use the handle provided.
  - Ensure fingers and other objects are never placed in any part of the vacuum cleaner. Clothing or hair may become trapped if the vacuum is used improperly.
-

- 
- Keep hair, loose clothing, jewellery, fingers and all parts of the body away from openings and moving parts.
  - Keep all air vents clear and free of dust, lint, hair and anything else that may reduce airflow.
  - Avoid directing the appliance towards naked flames as the air discharged may extinguish gas fires or pilot lights and may disturb ashes in open fires.
  - **DO NOT** Vacuum water or any other liquids with this vacuum.
  - **DO NOT** Vacuum hot ashes or lit cigarettes, etc.
  - Never use the appliance without the filter(s) in place.
  - **DO NOT** use the Vacuum with without the Dust Compartment attached.
  - **DO NOT** vacuum any large or broken objects such as glass.
  - **DO NOT** vacuum anything that is burning or smoking such as cigarettes, matches or hot ashes.

## Explanation of Symbols

The following warning symbols or words are used in this instruction manual:



Products labelled with UK Conformity Assessment identifies products conforming to UK statutory requirements.



Products labelled with this symbol conform to applicable provisions of the European Economic Area.

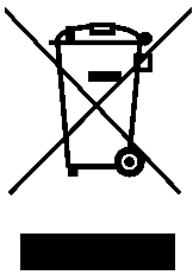

You should now recycle your waste electrical goods and in doing so help the environment. This symbol means waste electrical products at the end of their useful life should not be disposed of with normal household waste and not sent to landfill. Please ensure it is taken to a suitable facility for disposal. Check with your Local Authority or retailer for recycling advice or visit [www.recycle-more.co.uk](http://www.recycle-more.co.uk) or [www.weeeireland.ie](http://www.weeeireland.ie), enter your postcode to find out your nearest recycling site.

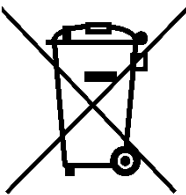

This symbol means batteries and rechargeable batteries may not be disposed of with household waste!  
As the end user you are required to bring all batteries and rechargeable batteries to a collection point run by the Local Authority or to a retailer, so that they can be disposed of in an environmentally friendly manner.



This symbol provides useful additional information on the use of this product.



This symbol indicates that the supply uses an alternating current mains supply.



This symbol identifies voltage and the current rating for direct current.



This designates a hazard with moderate risk, which may result in severe injury or damage to the product if not adhered to.

## Description of Parts & Accessories

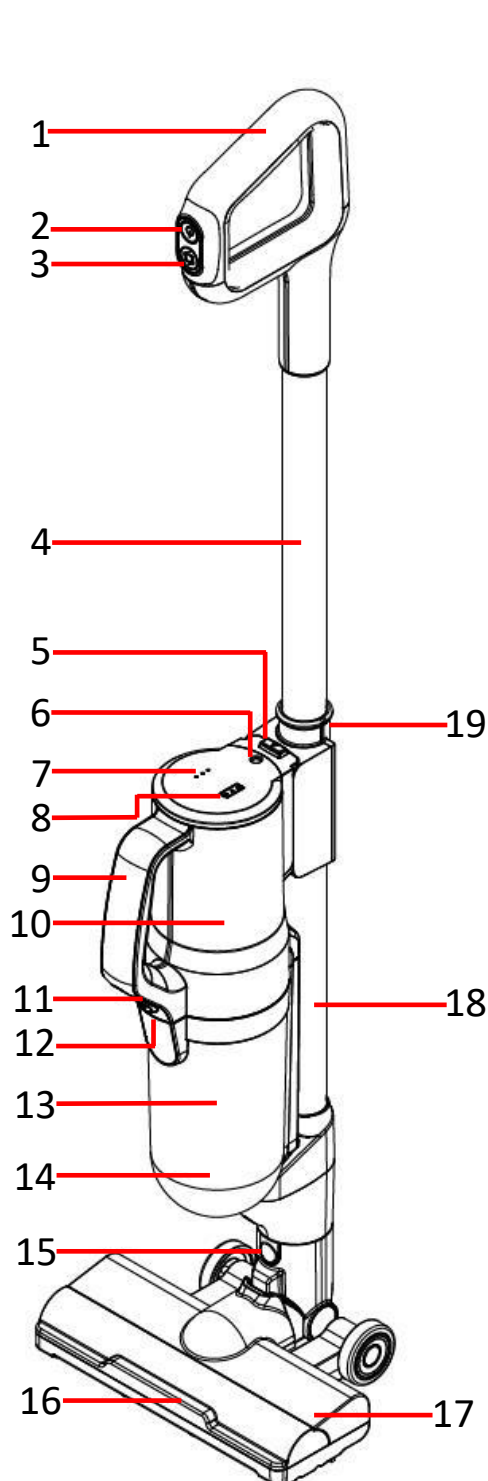

1. Handle
2. On/Off Button
3. Power Level Button
4. Handle Pole
5. Handheld Release Button
6. Charging Port
7. Power Level Indicators
8. Charge Level Indicators
9. Handheld Handle
10. Motor Unit
11. Handheld On/Off/Power Button
12. Dust Compartment Release Button
13. Filter Assembly
14. Dust Compartment
15. Floor Tool Release Button
16. Floor LEDs
17. Floor Tool
18. Lower Pole
19. Handle Pole Release Button
20. Multi Tool
21. Small Plug
22. Battery Charger

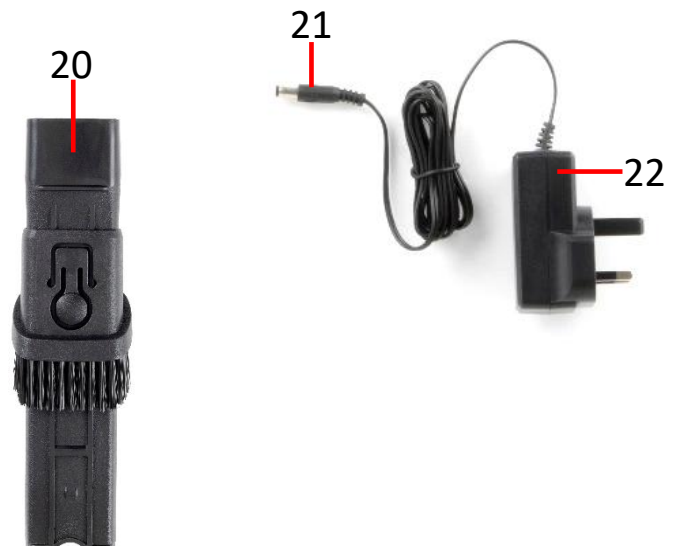

## Assembling Your Vacuum Cleaner

Assemble your vacuum cleaner using the four steps below:

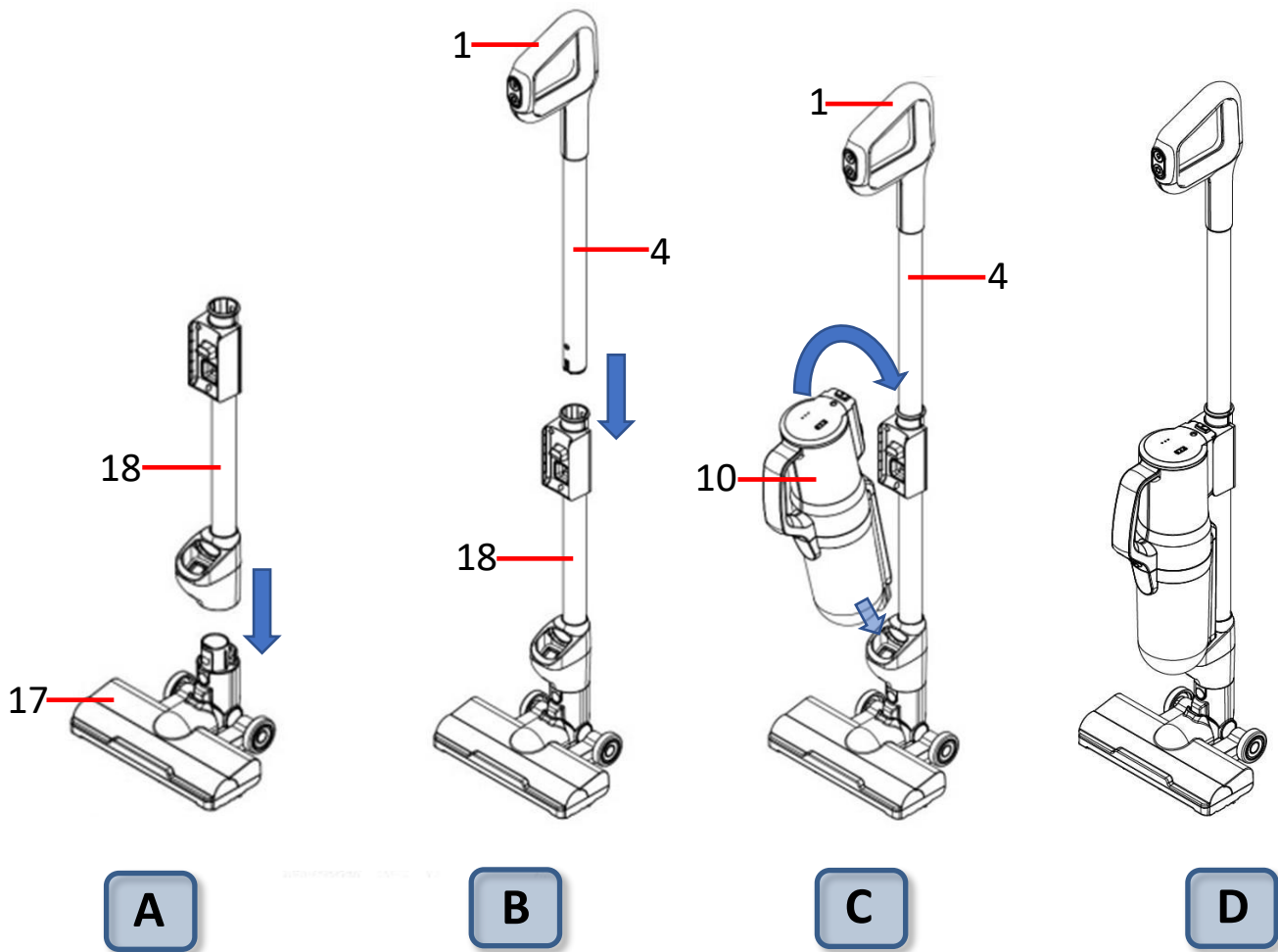

- A. Insert the **Lower Pole** (18) into the **Floor Tool** (17) as shown in 'A' above, push the pole down until it clicks home.
- B. Push the **Handle Pole** (4) into the top of the **Lower Pole** (18) until it clicks into place as shown in 'B' above.
- C. Insert the bottom of the **Motor Unit** (10) into the recess at the bottom of the **Lower Pole** (18) and lift towards the pole until it clicks into as shown in 'C' above.
- D. The Vacuum is fully assembled and ready to use.

### **Before first use of Your Vacuum Cleaner**

Remove all packing materials and discard responsibly.

Ensure that all parts are present – See **Description of Parts** above and that there is no damage to any component or the **Battery Charger** (22).

### **Charging the Battery**

*Before use, please ensure that the internal rechargeable battery is fully charged as follows:*

1. Insert the **Small Plug** (21) of the **Battery Charger** (22) into the **Charging Port** (6) on the top of the **Motor Unit** (10).
2. Plug the **Battery Charger** (22) into the nearest mains socket.
3. The **Charging Indicators** (8) will light in the sequence as in a, b, c below to show the internal battery is charging:

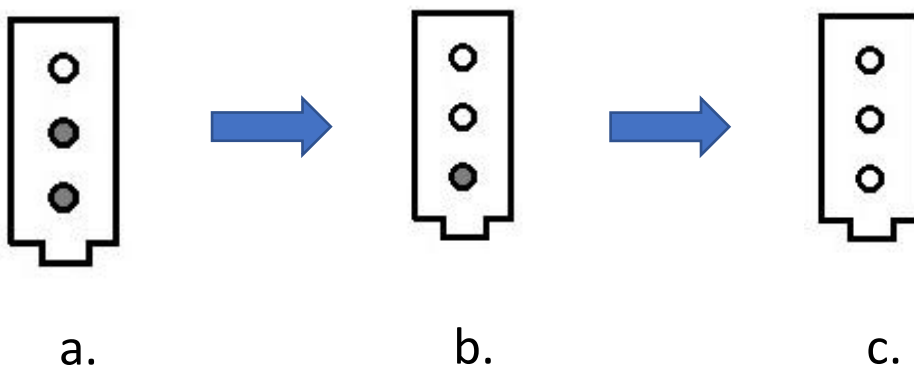

4. Once the battery is fully charged (after approximately 4.5 - 5 hours), the **Charging Indicators** (8) will have all LEDs fully lit as in 'c' above indicating that it is fully charged and the **Battery Charger** (22) can be removed and the vacuum used.

**NOTE** the vacuum cleaner cannot be used whilst connected to the charger.

**i** Whilst using your Vacuum Cleaner, the lights on the **Charging Indicators** (8) will slowly go out one at a time.

After a run time of approximately 40 minutes, all the **Charging Indicators** (8) will have gone out and the internal battery will require recharging as above.

### **Using Your Vacuum Cleaner**

1. To operate the vacuum cleaner, grip the vacuum by the **Handle** (1) and press the **On/Off Button** (2) at the top of the handle.

The vacuum cleaner will power up and the **Power Level** (7), the **Charge Level Indicators** (8) and the **Floor LEDs** (16) on the front of the **Floor Tool** (17) will illuminate.



**2**



**1**

2. Place your foot gently on the **Floor Tool** (17) and pull the cleaner back by the **Handle** (1) and start vacuum cleaning.

***Changing the Power level of Your Vacuum Cleaner***

Your vacuum will power up in medium power mode. To change the vacuum power level, press the **Power Level Button** (3) mounted on the **Handle** (1). Each press of the button will select low, medium or high power levels.

The power level selected will be shown by the **Power Level Indicator** (3) on the top of the **Motor Unit** (10) as shown below:

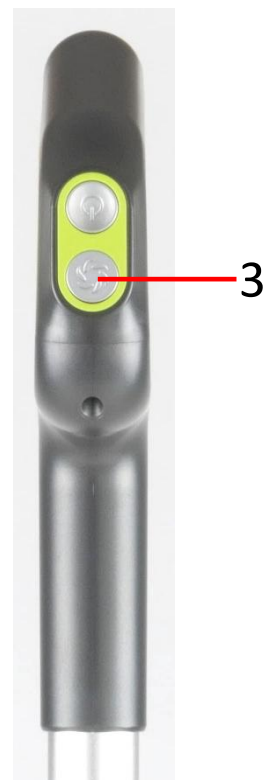
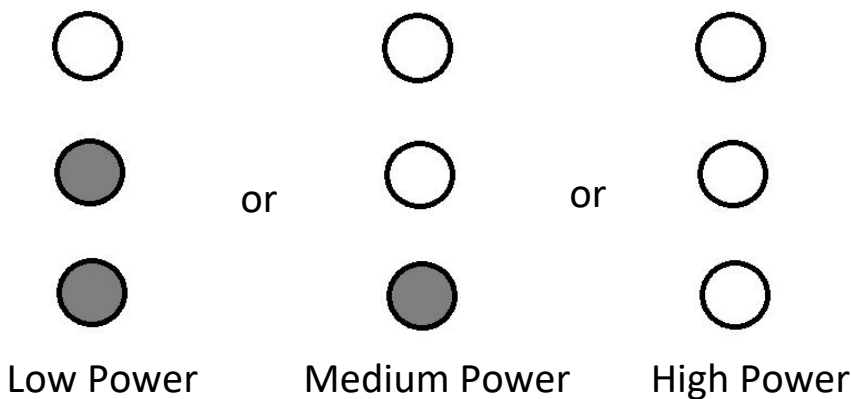

### Using Your Vacuum Handheld

To use your vacuum cleaner handheld, hold the unit by the **Handheld Handle** (7) then press the **Motor Unit Release** button (6) on top of the **Motor Unit** (10) arrowed in 'a'. Lift the handheld unit away from the vacuum as shown 'b' below:

a.



b.



### Attaching the Multitool (20)

Attach the **Multitool** (20) to the Handheld vacuum as shown below:



**Above:** The **Multitool** (20) can be used for cleaning upholstery and other hard to get at areas.

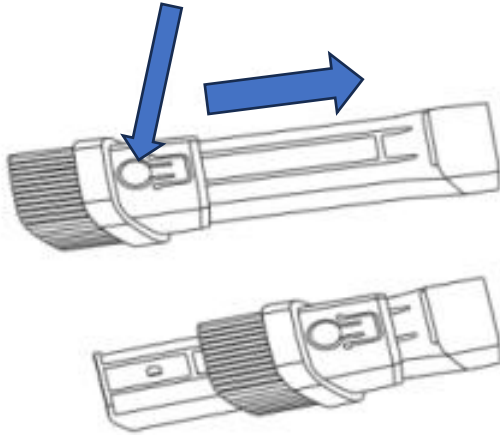

To use the **Multitool Tool (20)** without the brush, press the button (arrowed left) and pull the brush up.

Press the **Handheld On/Off/Power Button (11)** to power up the handheld Vacuum.  
 To change the **Motor Unit (10)** power level, press the **Handheld On/Off/Power Button (11)** again. Each press of the button will select low, medium or high power levels. Press the button once more to power down the handheld Vacuum.



### Emptying Your Vacuum Cleaner

1



1. Once the dust level reaches the 'MAX' mark on the **Dust compartment (14)** it will require emptying.

**⚠ WARNING!** **DO NOT** continue to use your vacuum cleaner once the 'MAX' mark has been reached as permanent damage may occur to the appliance.

2. Remove the Handheld Vacuum as described on page 11 – See *'Handheld Use'*.

To empty the cleaner, press the **Dust Compartment Release Button** (12) and remove the **Hepa Filter** (a) and the **Cyclonic Filter** (b) from **Dust Compartment** (14). Empty the contents into a waste bin.



**NOTE** support the **Dust Compartment** (14) whilst pressing the **Dust Compartment Release Button** (12) so that it does not fall.

To reassemble the Dust Compartment, see *'Reassembling After Cleaning'* on page 14.

Cleaning the Filter Assembly

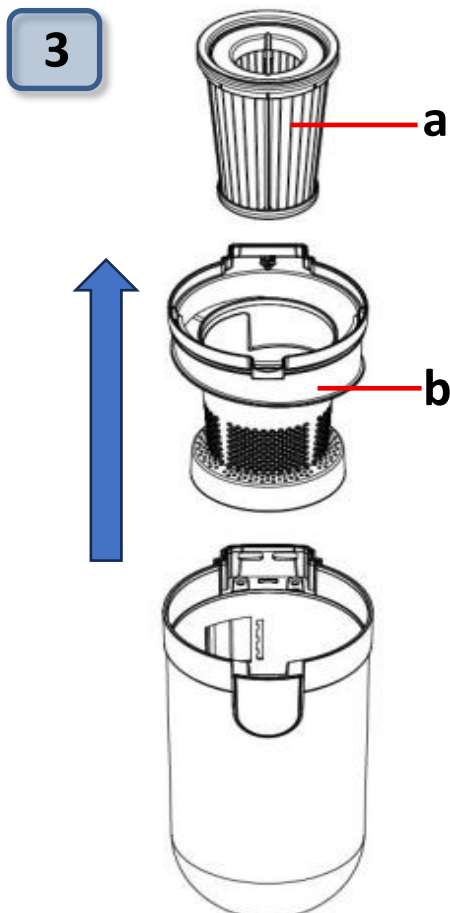

3. Remove the **Dust Compartment** (14) as described above.

Lift the **Hepa Filter** (a) out of the **Dust Compartment** (14). Hold the handle on top of the **Cyclonic Filter** (b) and lift it out of the **Dust Compartment** (14).

4

4. **Right:** Wash the **Hepa Filter (a)** in warm running water until clean. Allow the filter to dry thoroughly for 24 hours before reuse.



5

5. **Left:** Lift the handle up at the top of the **Cyclonic Filter (b)** and wash in warm running water until clean. Allow the filter to dry for 24 hours before reuse.



## Reassembling Your Vacuum

6. **Right:** Lower the **Cyclonic Filter (b)** into the **Dust Compartment (14)** and fold the handle flat.  
**NOTE** the smaller of the two tangs (shown inset right) is positioned to the front of the **Dust Compartment (14)**.

**DO NOT** replace the filters if they are damp or wet. Ensure they are thoroughly dry beforehand.

**⚠ WARNING!** **DO NOT** use your vacuum cleaner without the filters fitted as this will cause permanent damage to the cleaner.

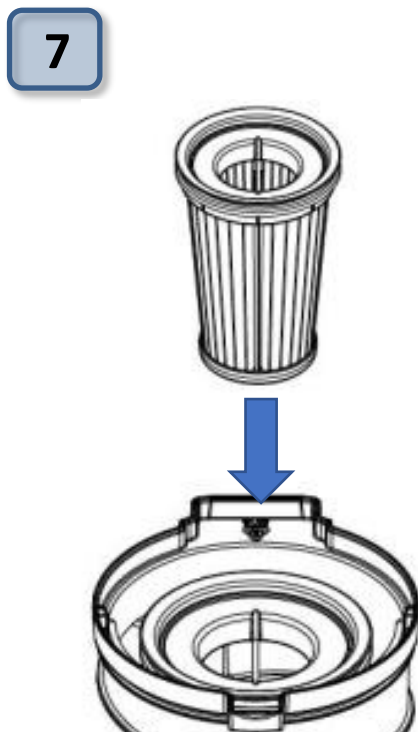
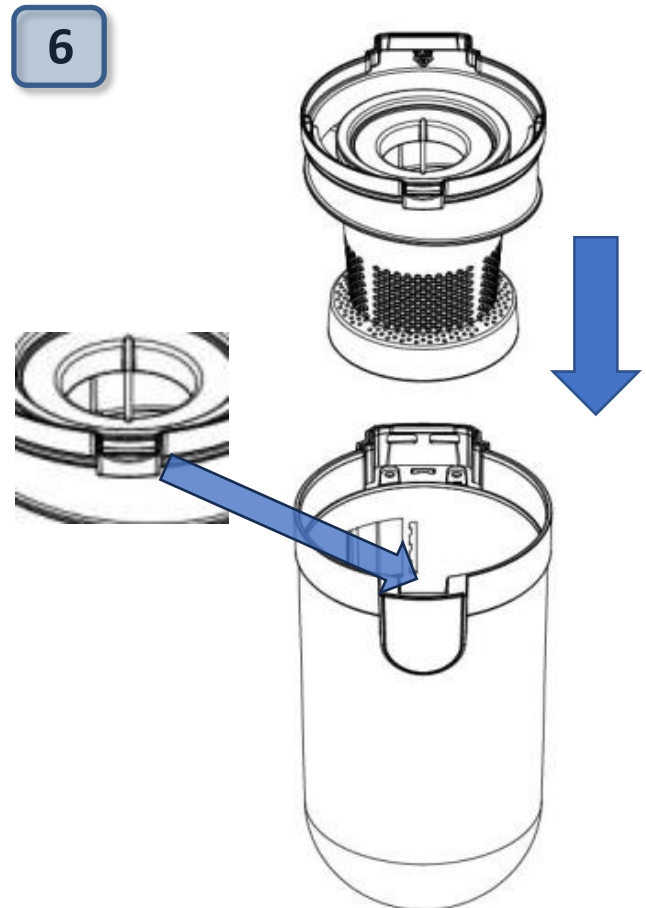

7. Insert the **Hepa Filter (a)** into the **Cyclonic Filter (b)**.

**8**

8. **Right:** Finally, re-attach the **Dust Compartment (14)** to the **Motor Unit (10)** by hooking the **Dust Compartment (14)** onto the rear of the **Motor Unit (10)** and then bring the front up until the catch clicks locked as shown right:

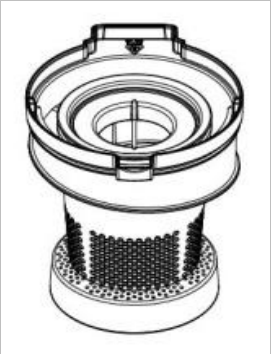

### ***Recommended Filter Cleaning Intervals***

<b><i>Filter Type</i></b>	<b><i>Recommended Cleaning Period</i></b>
Hepa Filter 	<ul style="list-style-type: none"> <li>• Shake out debris when you empty the dust container</li> <li>• Rinse under warm water once a month</li> <li>• Allow to dry thoroughly for 24 hours before reuse.</li> </ul>
Cyclonic Filter 	<ul style="list-style-type: none"> <li>• Shake out debris once a month</li> <li>• Rinse under warm water once a month.</li> <li>• Allow to dry thoroughly for 24 hours before reuse.</li> </ul>

**⚠ WARNING!** Ensure the filters are cleaned periodically according to the table above, failure to clean the filters regularly will severely impair the performance and permanent damage may occur to the appliance which may invalidate your warranty.

### Removing the Brush Bar for Cleaning

Remove the Brush Bar from the **Floor Tool (17)** as follows:

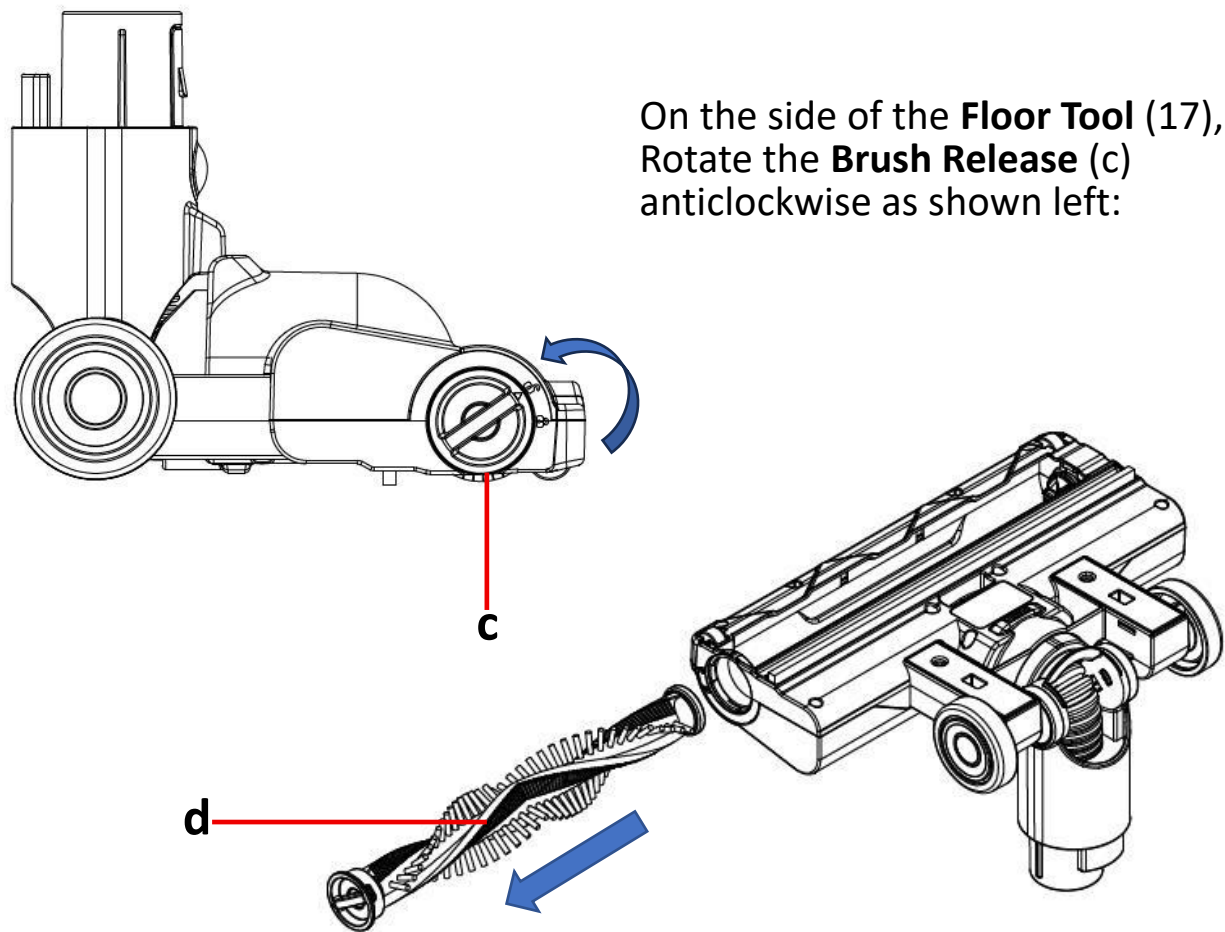

**Above:** Slide the **Brush Bar (c)** out sideways.

### Replacing the Brush Bar

Push the **Brush Bar (d)** back into the **Floor Tool (17)** and rotate the **Brush Release (c)** clockwise to lock the bar into place.

### Care and Maintenance of Your Vacuum Cleaner

- Always disconnect the cleaner from the battery charger before cleaning.
- Clean outside of the cleaner with a clean damp cloth. Never clean with harsh or abrasive cleaners.
- Do not submerge the cleaner in water or any other liquids.
- Empty the **Dust Compartment (14)** as soon as the 'MAX' mark has been reached.
- Wash the **Filter Assembly (13)** regularly – see table below.
- Allow the filters to thoroughly dry out for 24 hours before reassembly and use.

**⚠ WARNING!** DO NOT continue to use your vacuum cleaner once the 'MAX' mark has been reached as permanent damage may occur to the appliance.

### Storing Your Vacuum

Store the vacuum in a cool, dry place away from direct sunlight.

### Technical Specification

Model Number	FLR00225
Battery Charger	Input: 100-240V ~ 50/60Hz 0.5A (max.) Output: 26.6V DC --- 500mA 13.3W
Vacuum Rated Power	200W
Motor Type	BLDC
Battery	22.2V 2200mAh Li-Ion (6 cells)
Charge Time	4.0 – 4.5 hours
Run Time After a Full Charge	40 Minutes (max.)
Unpacked Weight	2.16 Kgs (approx.)
Filtration (Dust Compartment)	Hepa & Cyclonic Filter
Dimensions	20cm (d) x 24.2cm (w) x 105.5cm (h)
Vacuum	≥17kpa (max.)
Noise Level	≤76dB (approx.)
Dust Compartment Capacity	0.4L
Floor Tool Voltage Rating	22.2V
Floor Tool Power Rating	15W

## Troubleshooting Guide

<b>Problem</b>	<b>Possible Cause</b>	<b>Possible Solution</b>
Unit fails to turn on.	<p>Internal battery not charged.</p> <p>The <b>Battery Charger</b> (22) is not plugged into the mains socket.</p> <p>The <b>Small Plug</b> (21) of the Battery Charger is not plugged into the vacuum.</p>	<p>Charge the internal battery – see <b>Charging the Internal Battery</b> above.</p> <p>Ensure the battery charger is fully inserted into the mains socket and the socket is switched on (if applicable).</p> <p>Ensure the small round plug of the battery charger is plugged into the vacuum.</p>
Low suction or poor pick-up.	<p><b>Dust Compartment</b> (14) is full.</p> <p>Filters are clogged.</p> <p>Too lower Power setting selected.</p>	<p>Empty the Dust Compartment – see <b>Emptying Your Vacuum Cleaner</b> above.</p> <p>Check and clean the filters.</p> <p>Press the <b>Power</b> Buttons (3 or 11) to select a higher power setting.</p>
The vacuum is making a “hissing” sound.	The airflow is restricted.	<p>Empty the Dust Compartment.</p> <p>Check and clean the filters.</p> <p>Clear any blockages if necessary.</p>

---

## **Recycling Information**

### **Disposal of the Packaging**

Dispose of paper and cardboard in appropriate paper re-cycling facilities.

Dispose of recyclable plastics in appropriate plastic re-cycling facilities.

Dispose of non-recyclable plastics in the appropriate plastics collection service.

### **Disposal of the Product**

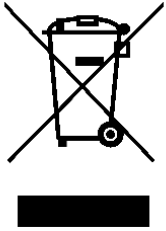

You should now recycle your waste electrical goods and in doing so help the environment. This symbol means waste electrical products at the end of their useful life should not be disposed of with normal household waste and not sent to landfill. Please ensure it is taken to a suitable facility for disposal. Check with your Local Authority or retailer for recycling advice or visit [www.recycle-more.co.uk](http://www.recycle-more.co.uk) or [www.weeeireland.ie](http://www.weeeireland.ie), enter your postcode to find out your nearest recycling site.

## ***Customer Support***

Should you require any product information, replacement parts or accessories, please contact our customer care team on 0161 831 7879 (8.30am-4.30pm Monday to Thursday, 8.00am-4.00pm Friday) and select option 3 or by contacting us via email: [help@daewooelectricals.com](mailto:help@daewooelectricals.com).

- Replacement parts and accessories are guaranteed for 1 year from the date of purchase.
- It is important to note that your warranty becomes invalid should non Daewoo parts or accessories be used with this appliance.

**UK  
CA**  

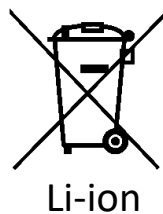
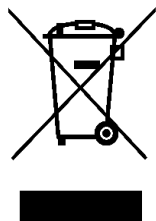

Li-ion

---

**Notes**



# DAEWOO®

## WARRANTY

*Thank you for purchasing your Daewoo Vacuum.*

*As part of our commitment to quality, we are offering you an extra 2 years warranty in addition to your 1 year guarantee*

Your Daewoo vacuum product is guaranteed for 1 year from the date of original purchase, with proof of purchase or receipt. If any defect should occur due to faulty workmanship or material, your faulty vacuum should be returned to the place of purchase, replacement or refund is at the discretion of the retailer.

The guarantee is subject to the following provisions:

- The product must be correctly installed and operated in accordance with the requirements contained in the instruction manual.
- The product must be used solely for domestic purposes.
- It does not cover general wear and tear, damage, misuse or any consumable parts.
- The guarantee will be rendered invalid if the product is re-sold or has been damaged through inexpert repair.
- The guarantee is only valid within the UK and Eire.

Your standard 1 year guarantee will only be extended to the maximum available for your individual product upon registration. (Note: products must be registered individually and covers the main body and housing). If you do not register your product within 28 days of the original purchase date, your product will only be guaranteed for 1 year.

*To validate your extended 2 year warranty\* please register your purchase online within 28 days of the original purchase date by registering at:*

<https://help.daewooelectricals.com>

or

[Contact Us \(daewooelectricals.com\)](https://www.daewooelectricals.com)

\*Your extended warranty is only valid with proof of purchase receipt and subject to the conditions outlined above.

Daewoo is a registered trademark.  
Produced and imported under licence by  
Eurosonic Group Limited  
Brightgate House  
1 Brightgate Way, Stretford,  
Manchester, M32 0TB, UK  
EU Rep: EuroSonic Magpie (ESM) Ltd. Ireland D05 X006  
[www.esgltd.com](http://www.esgltd.com)