

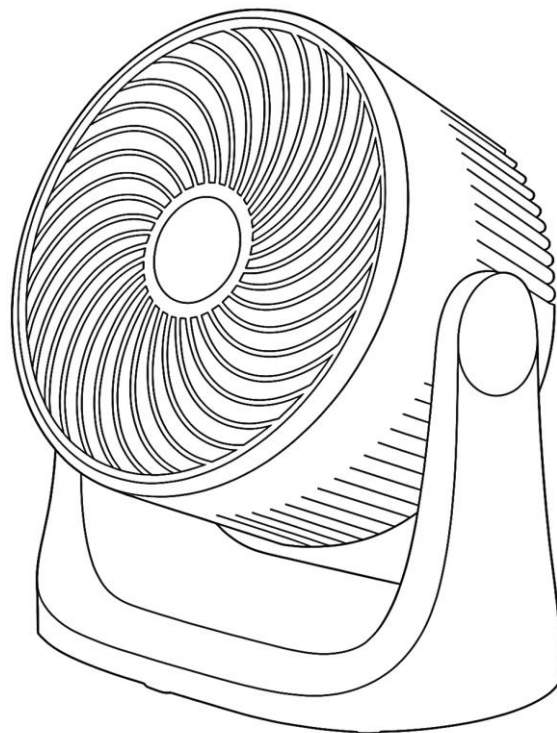

Desktop Air Circulator

COL1679
User Manual



Page	
2	Contents
3	Getting Started
3	Safety Advice
4	What's in the Box
5	Description of Parts
6	Assembly Instructions
7	Operating Instructions
8	Care and Cleaning
	Technical Specification
	Troubleshooting
	Recycling
9	Mains Plug
	Customer Support
Back Page	Warranty

1. Check that the product is intact and undamaged and all parts are present.
2. No tools are required to assemble your fan, though some assembly is required.

Safety Advice

- **IMPORTANT** – The first step you need to take is to ensure your safety! Please take time to read and understand these instructions before using the product.
- Please keep these instructions for future reference.
- This is a class II product and therefore does not require an earth connection.
- This appliance can be used by children aged from 8 years and above and persons with reduced physical sensory or mental capabilities or lack of experience and knowledge if they have been given supervision or instruction concerning use of the appliance in a safe way and understand the hazards involved. Children shall not play with the appliance. Cleaning and user maintenance shall not be made by children unless they are older than 8 years and with supervision.
- Close supervision is required when using this appliance near children.
- Keep the appliance and its cord out of reach of children less than 8 years.
- Children of less than 3 years should be kept away unless continuously supervised.
- **DO NOT** immerse the appliance or its cord in water or any other liquids.
- Always use this appliance on solid, level, surface.
- **DO NOT** use this appliance outdoors.
- Repairs to electrical appliances should be performed by a qualified electrician. Improper repairs may place user at serious risk.
- **DO NOT** operate this appliance with a damaged plug or cord, after a malfunction or after being dropped or damaged in any way.
- If the power cable is damaged, it should only be replaced by the manufacturer or a suitable qualified-after-sales service in order to avoid a hazard.
- **DO NOT** use any accessories or attachments with this appliance other than those supplied or recommended by the supplier.
- **DO NOT** use this appliance for anything other than intended use.
- **DO NOT** push objects (including fingers) into the fan grill or any openings as this could risk injury or damage to the appliance.
- Always unplug from the mains supply after each use when not in use. Grasp the plug not the cord.
- **DO NOT** leave this appliance unattended when in use.
- **DO NOT** dismantle the fan for cleaning.

- Desktop Air Circulator
- Instruction Manual (this booklet)

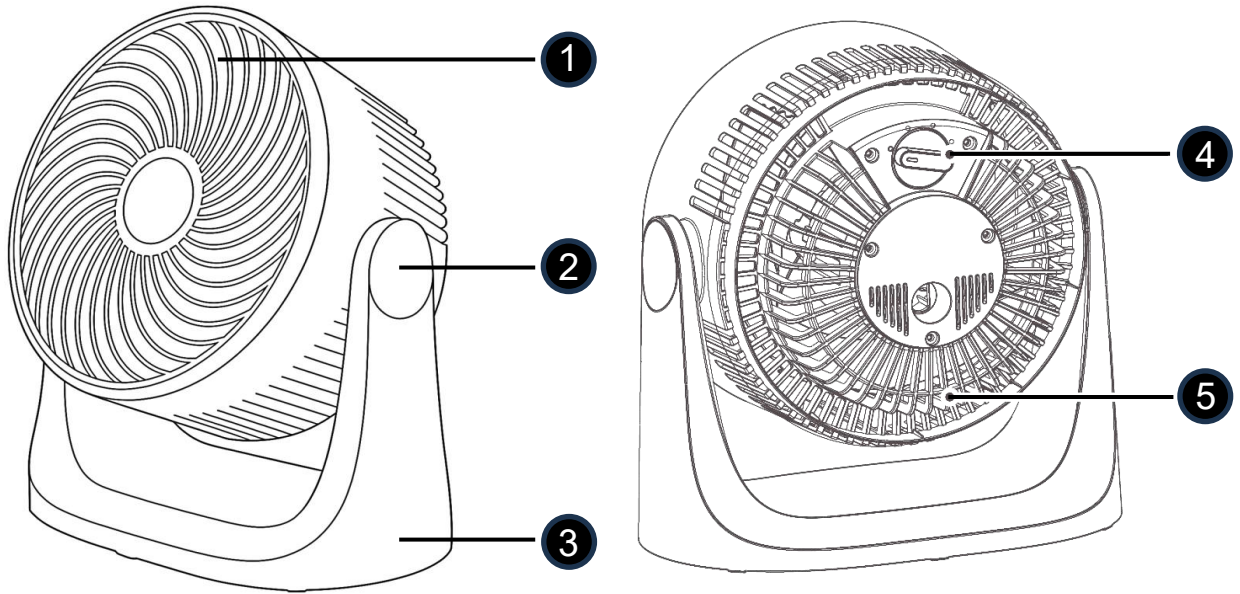

1. Fan Guard
2. Pivot
3. Base
4. On/Off/Speed Control
5. Rear Guard

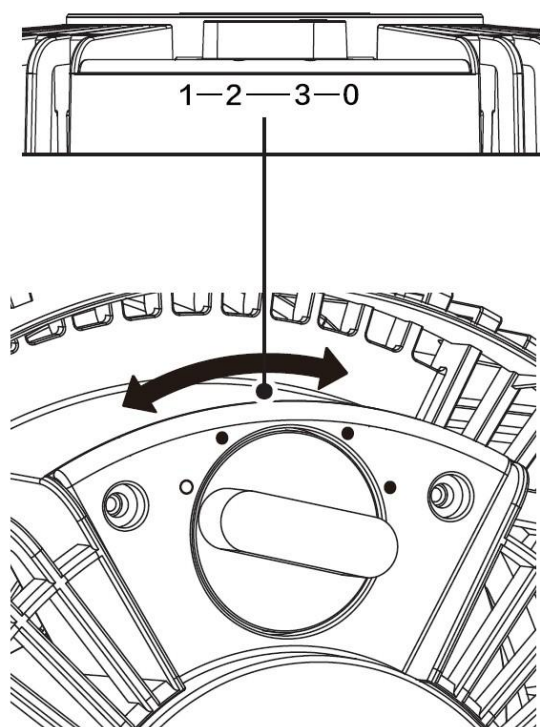

Step 1

Rotate the On/Off/Speed Control (4) to the off position '0'

Step 2

Place the fan on its Base (3) in the desired position ensure that it is on a solid, level surface.

Step 3

If desired, adjust the fans air flow by rotating the fan on its Stand Pivot (2) to the correct position.

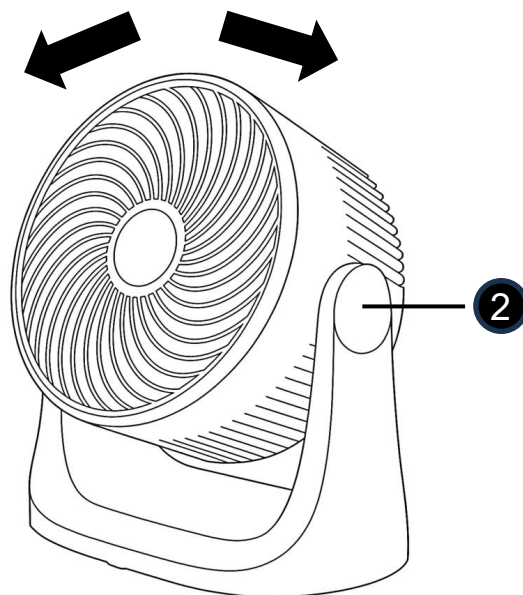

Step 4

Insert the mains plug into the nearest socket.

Rotate the On/Off/Speed Control (4) to the 1 position for the low speed.

Rotate the On/Off/Speed Control (4) to the 2 position for the medium speed.

Rotate the On/Off/Speed Control (4) to the 3 position for the high speed.

Rotate the On/Off/Speed Control (4) to the 0 position to switch the fan off.

Care and Cleaning

- Ensure that the fan is not connected to the mains supply before cleaning.
- We recommend cleaning the outer body with a soft dry cloth. Do not use abrasive materials as these will damage the finish.
- Do not immerse the fan or its cord in water or any other liquid.

Technical Specification

Model No.	COL1679
Voltage	220-240V~ 50Hz
Rated Power	28W
Protection Class	Class II

Troubleshooting

Symptom	Possible Solution
Fan not working	Check Mains Plug is in the socket and that the socket is switched on (if applicable)
	Check that On/Off/Speed Control is in the 1, 2, or 3 position

Recycling

Disposal of the Packaging

Dispose of paper and cardboard in appropriate paper re-cycling facilities.
 Dispose of recyclable plastics in appropriate plastic re-cycling facilities.
 Dispose of non-recyclable plastics in the appropriate plastics collection service.

Disposal of the Product

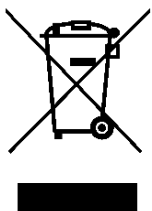

You should now recycle your waste electrical goods and in doing so help the environment. This symbol means waste electrical products at the end of their useful life should not be disposed of with normal household waste and not sent to landfill. Please ensure it is taken to a suitable facility for disposal. Check with your Local Authority or retailer for recycling advice or visit www.recycle-more.co.uk or www.weeeireland.ie, enter your postcode to find out your nearest recycling site.

This appliance is supplied with a non-rewireable plug fitted to the mains lead and should the fuse need replacing, you must use an ASTA approved one (conforming to BS 1362 of the same rating). Never use a mains plug with the fuse cover missing. If in doubt, consult a qualified electrician.

If the plug is to be removed – DISCONNECT FROM THE MAINS – and then cut it off the mains lead and immediately dispose of it safely. Never attempt to reuse the plug or insert it into a socket outlet as there is a danger of electric shock.

Item	Symbol	Unit	Tested
Maximum fan flow rate	F	m ³ /min	12.4
Fan power input	P _w	W	22.0
Service Value	SV	(m ³ /min)/W	0.6
Standby power consumption	P _{SB}	W	N/A
Seasonal electricity consumption	Q	kWh/a	7.0
Fan sound power level	L _{WA}	dB(A)	54.1
Maximum air velocity	C	meters/sec	4.2

Should you require any product information, replacement parts or accessories, please contact our customer care team on 0161 831 7879 (8.30am-4.30pm Monday to Thursday, 8.00am-4.00pm Friday) and select option 3 or by contacting us via email: help@daewoelectricals.com.

- Replacement parts and accessories are guaranteed for 1 year from the date of purchase.
- It is important to note that your warranty becomes invalid should non Daewoo parts or accessories be used with this appliance.



Thank you for purchasing your Daewoo product.

As part of our commitment to quality, we are offering you an extra 2 years warranty in addition to your 1 year guarantee

Your Daewoo product is guaranteed for 1 year from the date of original purchase, with proof of purchase or receipt. If any defect should occur due to faulty workmanship or materials, your faulty product should be returned to the place of purchase, replacement or refund is at the discretion of the retailer.

The guarantee is subject to the following provisions:

- The product must be correctly installed and operated in accordance with the requirements contained in the instruction manual.
- The product must be used solely for domestic purposes.
- It does not cover general wear and tear, damage, misuse or any consumable parts.
- The guarantee will be rendered invalid if the product is re-sold or has been damaged through inexpert repair.
- The guarantee is only valid within the UK and Eire.

Your standard 1 year guarantee will only be extended to the maximum available for your individual product upon registration. (Note: products must be registered individually and covers the main body and housing). If you do not register your product within 28 days of the original purchase date, your product will only be guaranteed for 1 year.

To validate your extended 2 year warranty* please register your purchase online within 28 days of the original purchase date by registering at:

<https://help.daewooelectricals.com>

or

[Contact Us \(daewooelectricals.com\)](https://www.daewooelectricals.com)

*Your extended warranty is only valid with proof of purchase receipt and subject to the conditions outlined above.

Daewoo is a registered trademark.
Produced and imported under licence by
Eurosonic Group Limited
Brightgate House
1 Brightgate Way
Manchester M32 0TB UK
EU Rep: EuroSonic Magppie (ESM) Ltd. Ireland D05 X006
www.esgltd.com
Made in China